

The image features two industrial robot arms from the Hexergo AE3 Series. One arm is black and positioned on the left, while the other is silver and black, positioned on the right. They are set against a plain white background. The text 'hexergo 慧想' is located in the top left corner, and 'AE3 Series' is written in large, light grey letters across the bottom, partially obscured by a teal horizontal bar.

hexergo[®] 慧想

AE3 Series

MOVE TO CREATE

创 随 心 动

| AE3 系列

产品简介 Product Introduction

作为国内人体工学产品的领导者之一，慧想推出了全新一代显示器支架 AE3。使用了突破性的双腔弹簧技术，可以支持 9kg 内的显示器丝滑调节。出色的工业设计与丰富的拓展配件，让它能无缝融入几乎任何使用场景。

As one of the ergonomic products leaders in China, Hexergo has launched a new monitor arm AE3. It uses breakthrough dual-chamber spring technology to support smooth adjustment of monitors within 9kg. Its outstanding industrial design and wide adaptability allow it to seamlessly integrate into almost any environment.

产品特点 Product Features

双腔弹簧技术 Dual-Chamber Spring Technology

头部采用独家专利——双腔弹簧技术，进一步提高调节丝滑度，为显示器提供双倍俯仰支撑，持久保障不沉头。

The head adopts the exclusive patent — dual-chamber spring technology to further improve the smoothness of adjustment, provide double support force for the display, and lastingly guarantee it not tilting down.



产品特点 Product Features

机械弹簧结构 Minimalism Aesthetic Design

专利机械弹簧结构，稳固支撑的同时，全域支持一指调节。

Patented mechanical spring structure provides stable support while allowing effortless one-finger adjustment on the entire arm.



产品特点 Product Features

铝合金一体压铸 Aluminum Alloy Monolithic Die Casting

下支臂采用铝合金一体压铸，进一步保证支撑结构强度。

The lower arm is made from a single-piece aluminum alloy diecasting, further enhancing structural strength.



产品特点 Product Features

贯穿式走线仓 Perforative Cable Cover

下支臂采用中空设计，配有前后进线和出线口。

The lower arm adopts hollow design with front and rear inlet and outlet.

产品特点 Product Features



快挂式VESA结构 Fast Hanging Vesa Structure

巧妙的快挂设计，让单人显示器安装变得易如反掌。

The clever fast hanging design makes the display installation easier by just one person.

规格信息 Specification Information

产品参数 Specifications

| | | | |
|---|--------|--|-------------------------|
|  显示器尺寸 LCD size | 17~34" |  俯仰角度 Tilt | +45~-15° |
|  承重范围 Wt.Capacity | 2-9kg |  升降 Lifting height | 255mm |
|  旋转角度 Pivot | 360° |  VESA | 75×75 100×100 |
|  左右摆动 Swivel | ±90° |  穿夹桌面厚度 Desk Thickness | 穿孔：0-80mm 夹具：10-80mm |

安装方式 Installation Method



桌面锁定
Upper Locking



穿孔
Grommet Mount



夹持
Clamp

可选颜色 Selective Color



● 曜石黑
Black



○ 星云白
White



● 超星红
Red



● 彗星银
Silvery

产品线延伸 Product Line Extension

| 部位 | 可选零件 | | | | | |
|--|--|---|--|---|--|--|
|  <p>上支臂 Upper Arm</p> |  <p>动臂+vesa头 Arm+Vesa Head</p> |  <p>动臂+滑轨头 Arm+Slide Rail Head</p> | | | | |
|  <p>下支臂 Lower Arm</p> |  <p>固定臂 Fixed Arm</p> |  <p>固定横臂 Fixed Cross Arm</p> |  <p>下动臂 Lower Arm</p> | | | |
|  <p>底座 Base</p> |  <p>单屏底座 Single Arm Base</p> |  <p>单屏桌面锁定底座 Single Arm Upper Locking Base</p> |  <p>双屏桌面锁定底座 Dual Arm Upper Locking Base</p> |  <p>高杆底座 High Pole Base</p> | | |
|  <p>其他配件 Other Accessories</p> |  <p>双屏底座盖 Dual Arm Base Cover</p> |  <p>30mm增高柱 Height Increasing Column</p> |  <p>高杆转接件 High Pole Adapter</p> |  <p>双臂拓展件 Dual Arm Extension</p> |  <p>330mm高杆 High Pole</p> |  <p>190mm高杆 High Pole</p> |

产品线延伸 Product Line Extension

单屏系列

Single Series

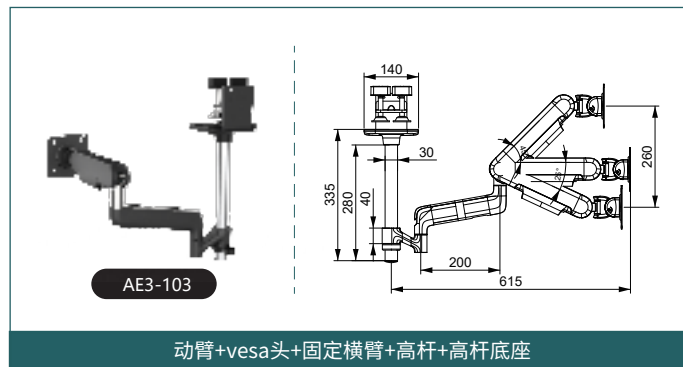
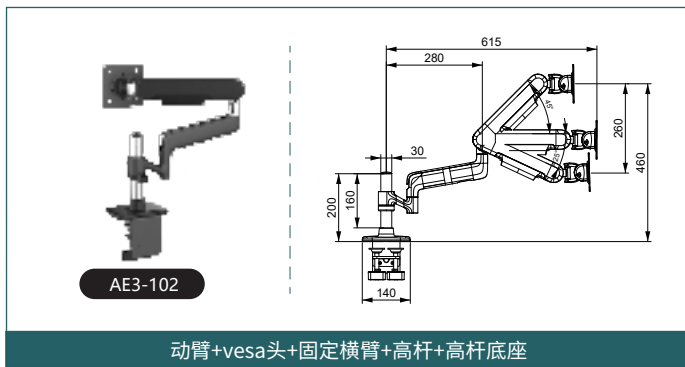
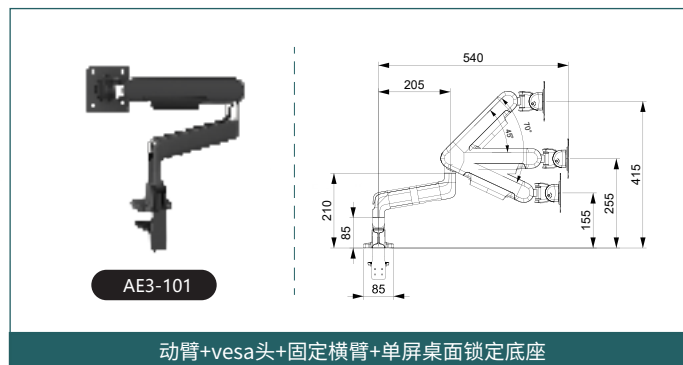
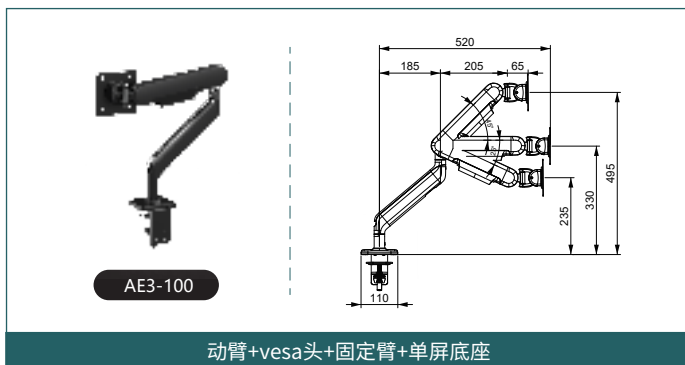

产品线延伸 Product Line Extension

双屏系列

Dual Series

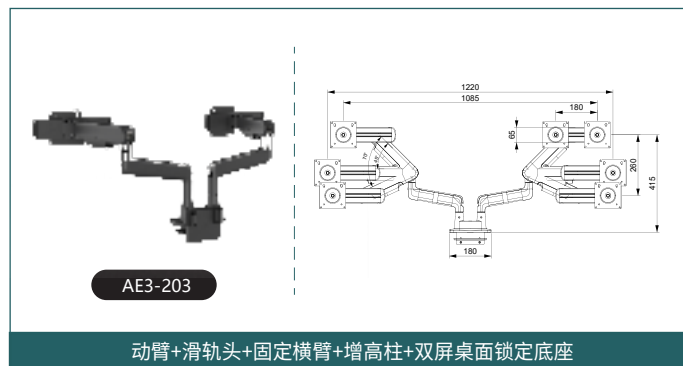
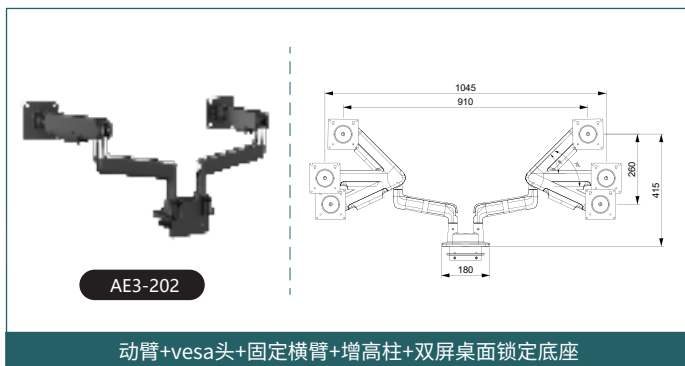
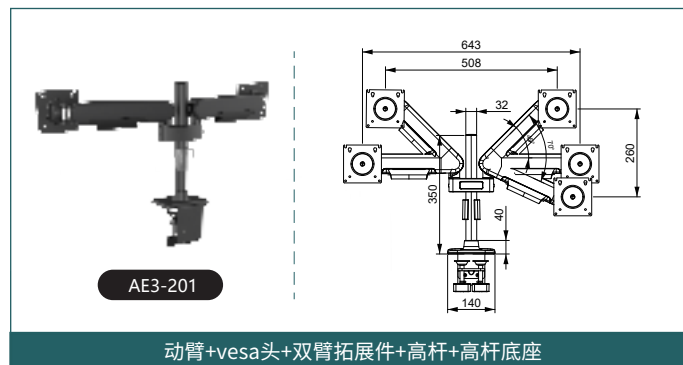
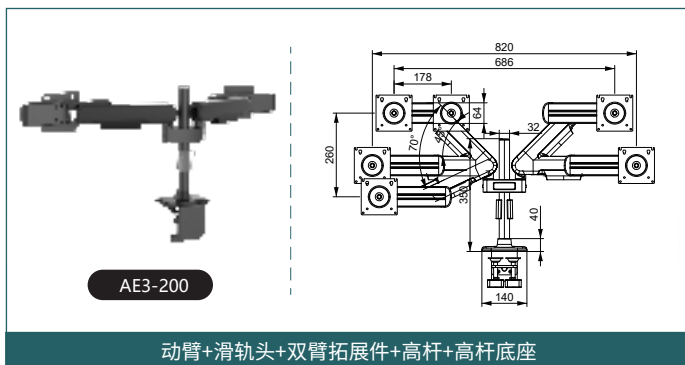

产品线延伸 Product Line Extension

双屏系列

Dual Series

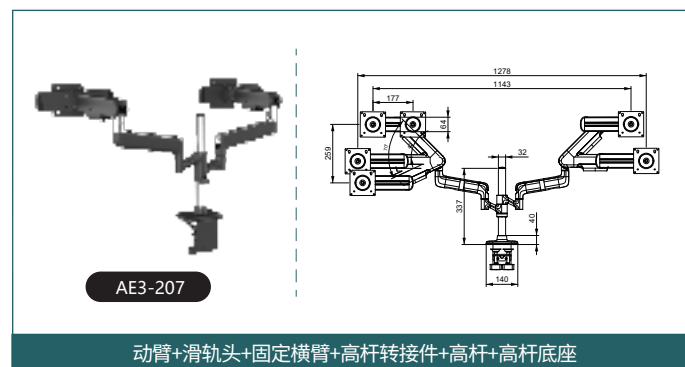
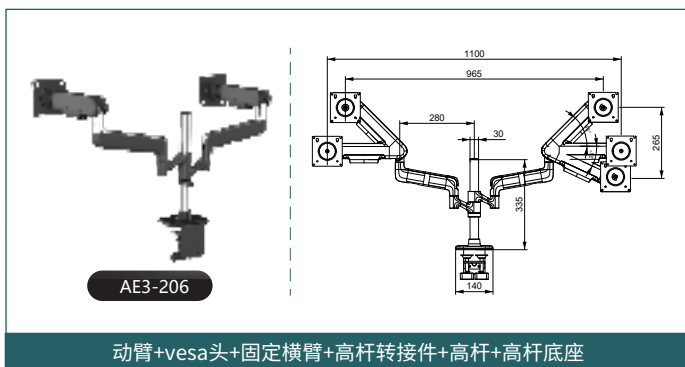
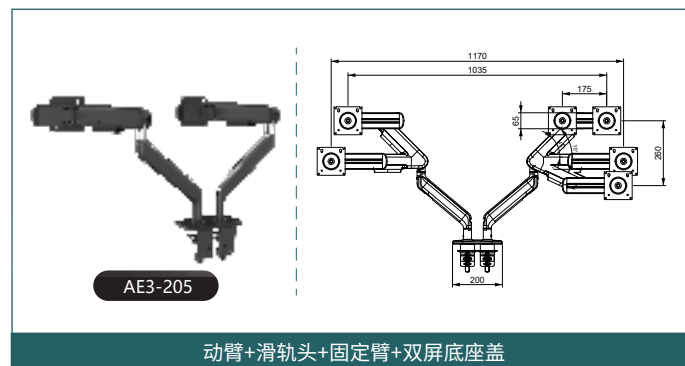
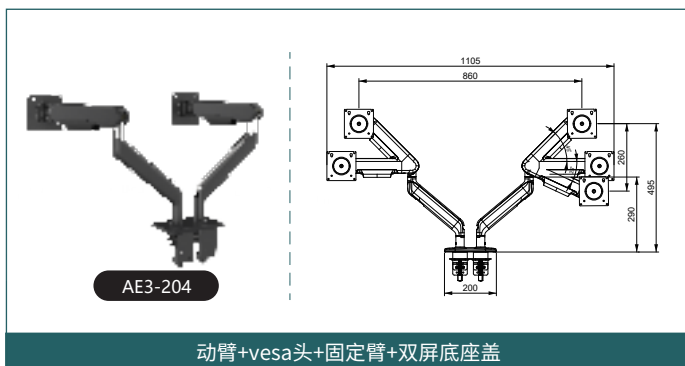

产品线延伸 Product Line Extension

双屏系列

Dual Series

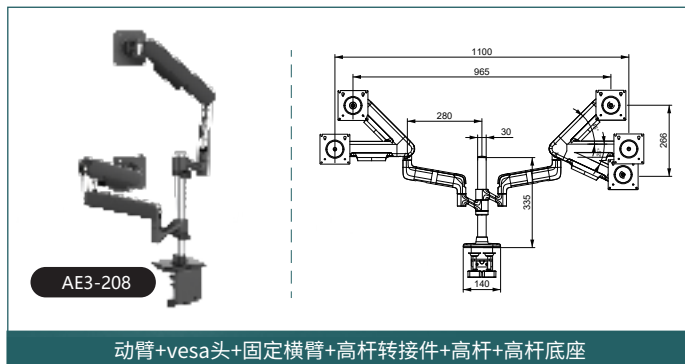









400-600-5155
上海新慧想科技有限公司

SHANGHAI NEW THINKWISE TECHNOLOGY CO., LTD